

**+30**  
YEARS of  
Expertise

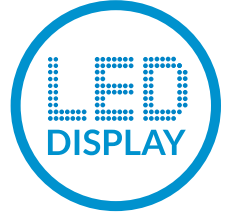

Made in EU



# HYMN series

LED HYMN BOARDS FOR CHURCHES  
2 AND 10 LINES

High-resolution  
LED matrix



Control via  
app or radio

© 2025 Phoenix Professional Audio GmbH | All rights reserved - Pictures, design and colors may vary. Subject to technical modifications, errors excepted.

DOC-250312



www.phoenix-pa.com

Top features:



# HYMN series

LED hymn boards, 2 and 10 lines  
Control via app or input device

**LED MATRIX** **READING DISTANCE UP TO 70M**  
**FLAT DESIGN** **16.7 MILLION RGB COLORS**

Contemporary technology at the highest functional level: Discover the unique, modern "HYMN" LED hymn boards for churches and communities with 2 lines (HYMN-1 series) or 10 lines (HYMN-5 series), each with 5 digits, and optional control via tablet<sup>1)</sup> (including app and software) or via an input device<sup>2)</sup>.

SPECIALS:  
HYMN



Elegant, ultra-flat display board including multi-swivelling wall mount



Excellent readability up to 70 meters thanks to high-resolution LED matrix (dot matrix display)



Colorful, alphanumeric display per line selectable in approx. 16.7 million RGB colors



Uppercase, lowercase and special characters



Incl. 7" Android tablet with pre-installed control app



Control also possible via input device



Excellent radio range: up to 300 m in open field



Display run-through before the service



Suitable for listed buildings (stand solution)



Numerous accessories (wall mounts, stands, power batteries and much more)

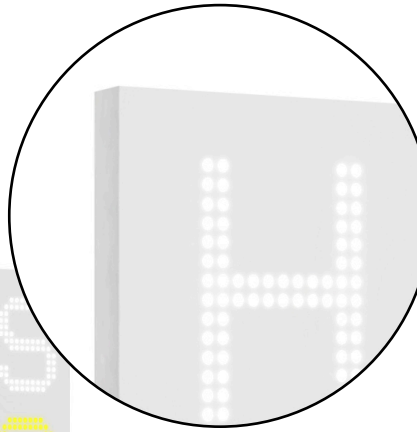

High-resolution  
**LED**  
matrix



HYMN-5-110

HYMN-1-180

Fig.: left 10-line hymn board of the HYMN-5 series; right 2-line hymn board of the HYMN-1 series

The state-of-the-art electronics and robust housing used in our hymn boards guarantee longevity, interference-free operation and excellent readability – even from a distance and in daylight.

\* Models of the HYMN-1-APP and HYMN-5-APP series  
\*\* Models of the HYMN-1-E and HYMN-5-E series



**HYMN series** - Continued from previous page

The "HYMN" series offers you a **wide range of different model sizes**, suitable for installation in small churches and even large cathedrals.

Choose the model that suits you best from our extensive portfolio:

The range includes **smaller hymn boards for the choir and chancel area** as well as **medium and large main hymn boards** with an unrivalled **variety of display and customization options**.

The **2- and 10-line displays** are designed for reading distances of around **15 to 70 meters** and have a **character height of 40 to 180 mm** (depending on the model).

In combination with the **high luminosity** of the LED light diodes, the **high-resolution matrix** guarantees **perfect readability** – even from a long distance. The **large, rounded numbers and letters** are also very easy to read by older people (**dot matrix display**, not a 7-segment display).

Fig.: up hymn board HYMN-1-70

## Good to know

The "HYMN" hymn board comes with a **complete SET** (scope varies depending on the model):

- LED display
- Power pack for power supply
- Wall mount with mounting kit
- Operating instructions
- Tablet with app or input device (acc. to your order)



Fig.: Scope of delivery of the HYMN-1-70 APP model

A **special surface technology** prevents any reflection, so that even lamps or light-flooded rooms do not affect the readability. The **built-in automatic brightness** always ensures a perfect reading result – regardless of whether the hymn board is placed in a bright area or a dark side altar.

© 2025 Phoenix Professional Audio GmbH | All rights reserved – Pictures, design and colors may vary. Subject to technical modifications; errors excepted.

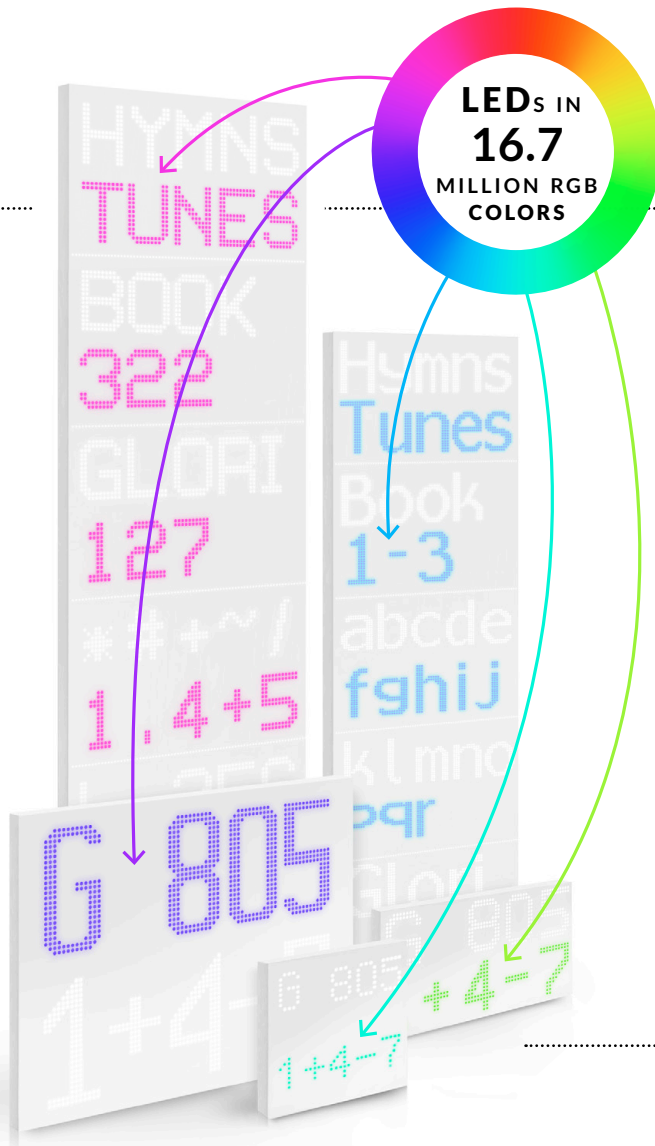

## LED luminous digits in countless RGB colors

The "HYMN" hymn boards are unique in their diverse presentation options:

They allow you to use **upper and lower case letters, special characters** and a **free choice of color** for lines 1 and 2. Using the software, the color of the illuminated digits can be individually set in around **16.7 million RGB colors** per line.

### Get creative!

Different colors can be selected for the **song number** and the **verse**. This gives you the option of **coloring each display line separately** in countless RGB colors.

Fig.: right Individual color setting in the HYMN control app



HYMN series - Continued from previous page

The front panel of the "HYMN" hymn board is **pure white**, both when switched on and off. When the display is not in use, it is **completely opaque** and barely noticeable on a white wall.

Thanks to their stable yet very **unobtrusive and ultra-flat design** (housing only approx. 30 mm deep), the "HYMN" hymn boards blend harmoniously into any architecture.

The "HYMN" series offers the user a **high level of flexibility and easy handling**: Our systems are **modular** and therefore suitable for all applications.

The delivery includes the **multi-swivelling HYMN-V-1 bracket** (e.g. for wall mounting in the church).

However, the concept of our systems is not only based on **stationary use**. If you want to use the hymn board in a small chapel, outdoors or in a listed building without electricity, we offer optional **power supplies and matching stands** that enable a completely **self-sufficient use**.

When switched on and off, the background of the display is **pure white**

Fig.: left Stand solution for the "HYMN" hymn boards

**SPECIALS:**  
Control



**Control via input device:**  
Touch display in an elegant housing



**Control via app:** including tablet and accessories (full version); suitable also for other Android devices



**Easy to use and clear display**



**No WLAN /WiFi is required on site**



**Powerful battery** (approx. 10 hours operating time)



**Free color setting** for line 1 and line 2



**Timer function**



**Individually adjustable brightness** for input device and hymn board



**Display lighting:** Operation possible even in the dark

## Easy control

**Equipped for the technology of the future:** The "HYMN" hymn boards are either operated via a **tablet with a pre-installed app** or controlled via an **input device** ("basic systems"). **Operating** the hymn boards is as **intuitive and easy** as making a phone call with your smartphone. Choose the control that is best suited to you!

By the way, **no WLAN is required** on site: The hymn boards have their **own radio system set up via a gateway**, which can also be integrated into existing WLAN systems (see graphic "How the hymn board gateway works" (Appendix A)).

Hymn boards with input device:

- HYMN-1-E series (2-line)
- HYMN-5-E series (10-line)

Hymn boards with tablet / software incl. app & accessories (full version):

- HYMN-1-APP series (2-line)
- HYMN-5-APP series (10-line)

Fig.: left Input device in the color "white marble" right App control via tablet



HYMN series - Continued from previous page



With the "HYMN" hymn boards, we offer you well thought-out and high-quality products that are designed to achieve a long and trouble-free working life.

The "HYMN" series offers you the freedom to combine 2- and 10-line displays. You can add as many extensions as you like.

Complete your basic set with, for example, a choir display, a small display for monitoring in the chancel or another additional hymn board to equip larger church rooms (extension modules HYMN-M).

There are hardly any limits to your possibilities!

All models in the 2-line HYMN-1 series can be easily combined with all models in the 10-line HYMN-5 series.

The 10-line "HYMN" hymn boards are available in three sizes and were not only developed for large church rooms. Rather, even smaller communities make use of the many conveniences of a multi-line hymn board.

Further information on the different models and the control system can be found on the following pages of this brochure and in our online shop >>

# Run-through function

Display PREVIEW

The sequence of the planned songs can be conveniently programmed in advance so that the prepared program can be easily called up during the service.

A useful run-through function informs church visitors about the selected songs and verses before the service. This allows the church community to prepare the hymn books BEFORE the service.

The run-through function can be easily activated via the app or the input device. The song numbers and verses you enter using this function appear one after the other on the hymn board. Up to 20 displays are available in the 4 existing memories.

The prepared program can of course be sent to several hymn boards at the same time. Several input devices can also be used in parallel. The radio transmission even works without a direct view of the board.

On the control unit you can see what is currently being displayed and you can use the slider to set the display duration (2 seconds to 30 seconds).

As soon as the service begins, you can easily stop the run-through function again with the help of the control unit.

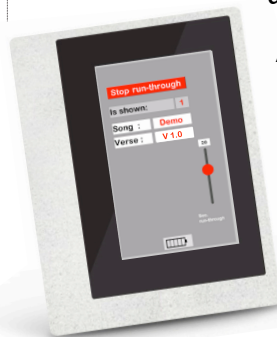

## A CLOSER LOOK AT HYMN-1-100

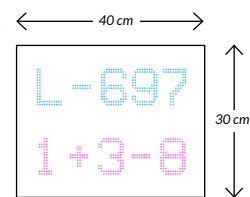

2-LINE 35-40 M ABCDE 12345 A 100 MM

The HYMN-1-100 model is a 2-line LED hymn board (2-way display) with a reading distance of up to 35-40 m. The high-precision 13x25 matrix<sup>\*)</sup> makes this model a perfect main display.

Dimensions (W x H x D): 40 x 30 x 3 cm.

Color (housing / front): pure white.

It is controlled via an input device (version HYMN-1-100-E) or via tablet / software including app & accessories (version HYMN-1-100-APP).

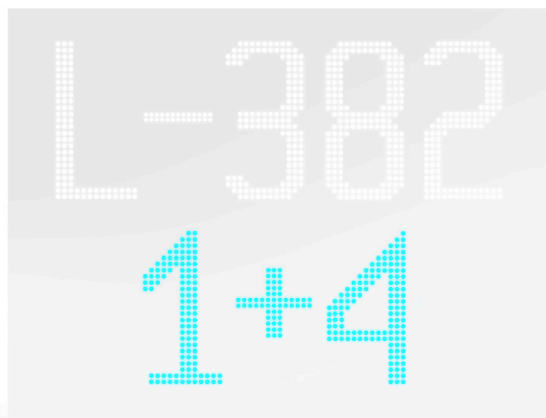

\* The individual digits consist of 13 columns and 25 rows each (a total of 325 luminous dots)



The LED light diodes used in the "HYMN" hymn boards impress with their **high energy saving potential** and their **very long service life**.

By using the highest quality components, sophisticated assembly techniques and tried and tested tablets, we guarantee a **trouble-free, long-term use** at the highest level. **Manufactured in Europe**, our hymn boards are developed according to the **strictest quality criteria** and meet all common standards.

Make singing together even more enjoyable with the "HYMN" hymn boards from Phoenix!



Digital hymn boards make a significant contribution to ensuring that everyone can enjoy the service together. They **motivate church visitors to sing along** and encourage them to **participate actively**.

By displaying the current song number and verse, the church community always knows where to look up the song in the hymn book and sing along.

HYMN advantages



**High energy saving potential** of the LED light diodes used



**Very long product life**



**Highest quality** through the use of high-quality components



**Sophisticated assembly techniques**



**Trouble-free, long-term use**



**Development according to the strictest quality criteria**



**Compliance with all common standards**



**Premium quality MADE IN EU**

A CLOSER LOOK AT HYMN-5-70



10-LINE



20-25 M



A 70 MM

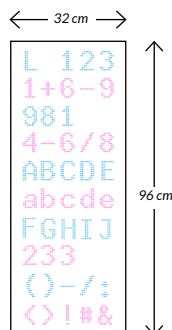

The model **HYMN-5-70** is a **10-line LED hymn board** (5-way display) with a **reading distance of up to 20-25 m**. The high-precision **15x21 matrix**<sup>\*)</sup> makes this model a perfect **main display**.

Dimensions (W x H x D): **32 x 96 x 3.5 cm**.

Color (housing / front): **pure white**.

It is **controlled** via an **input device** (version **HYMN-5-70-E**) or via **tablet / software including app & accessories** (version **HYMN-5-70-APP**).

\* The individual digits consist of 15 columns and 21 rows each (a total of 315 luminous dots)

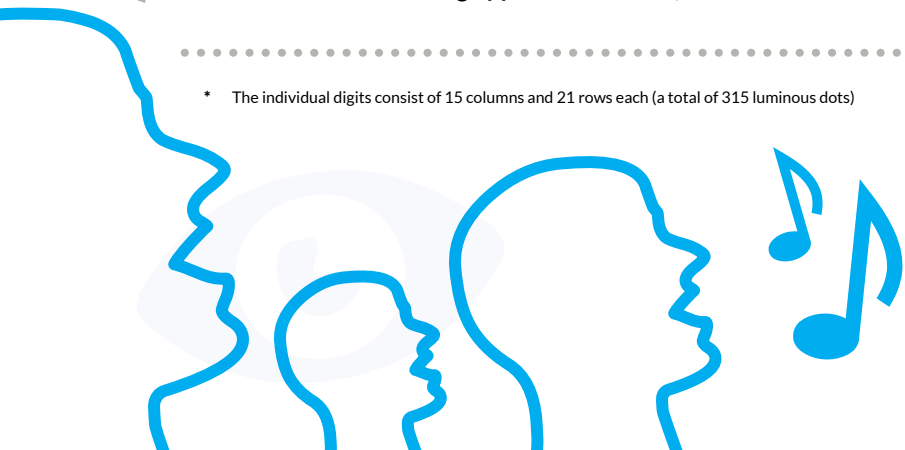
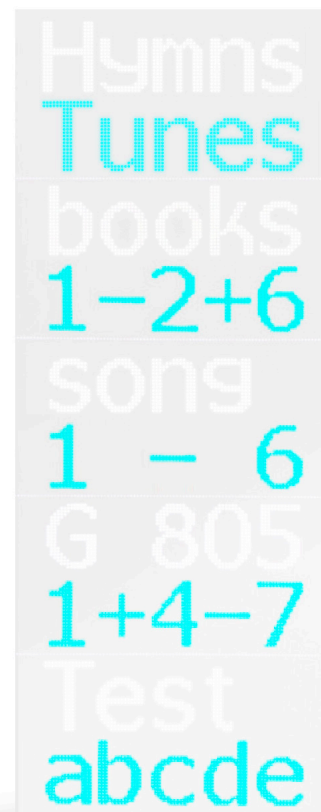



Another great advantage of the "HYMN" hymn boards is that not only one or two numbers can be displayed in advance, as is the case with classic "analog" hymn boards.

Thanks to the run-through function up to 20 song numbers and verses are displayed one after the other at certain intervals before the service. Thus, the church community can open all the songs in the hymn book in advance, mark them with ribbons, for example, and perfectly prepare for the service.

With the "HYMN" hymn boards, church visitors are guaranteed to not miss a song and the service becomes an exciting experience for everyone!

## Special custom solutions

We can provide you with the right solution for every structural requirement.

We are happy to adapt the appearance of our systems to your specific needs. For example, the edges of the hymn board can be supplied in a special color so that they match the wall color of your church perfectly and blend harmoniously with the room.

We also offer you special technical solutions for special requirements where possible:



Fig.: VESA mount HYMN-V-QR

Maybe you would like to mount two hymn boards on a swivel arm at the same time? Then the quick-release VESA mount HYMN-V-QR is the ideal solution: The quick release allows you to easily remove the hymn boards from the holder (or a wall) and swap them around flexibly.

Please feel free to contact us if you have any special requests!



### OUR service



Personal support and reliable customer service



Detailed advice on every project



Development of individual plans according to your requirements



Sales and service worldwide



Fast and competent support



Easy procurement of spare parts even after many years

### A CLOSER LOOK AT

## HYMN-1-40



2-LINE



8-12 M



40 MM

17 cm

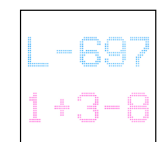

The HYMN-1-40 model is a 2-line LED hymn board (2-way display) with a reading distance of up to 8-12 m. Due to the coarser 5x7 matrix<sup>\*</sup> it is suitable as a choir display or is used as a small additional display for monitoring in the chancel area e.g. for pastors and altar servers.

Dimensions (W x H x D): 17 x 17 x 3 cm.

Color (housing / front): pure white.

Important: The hymn board is only available as an extension module without an input device (for combination with a main display) (version HYMN-1-40-M).

\* The individual digits consist of 5 columns and 7 rows each (a total of 35 luminous dots)



HYMN series - Continued from previous page

# The models

Overview

## HYMN-1 series

2-LINE 8-70 M → ABCDE 12345 A ↑ UP TO 180 MM

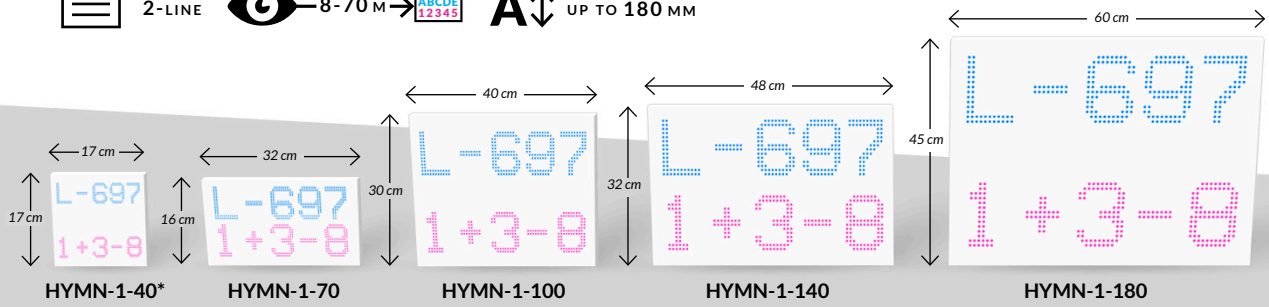

## HYMN-5 series

10-LINE 12-54 M → ABCDE FGHIJ KLMNO PQRST UVWXY Z 1234567890 A ↑ UP TO 110 MM

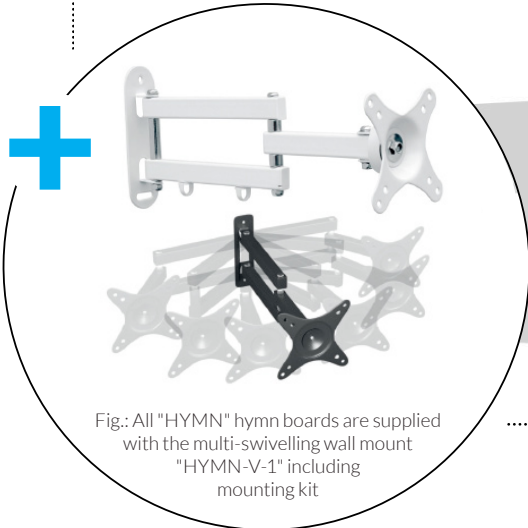
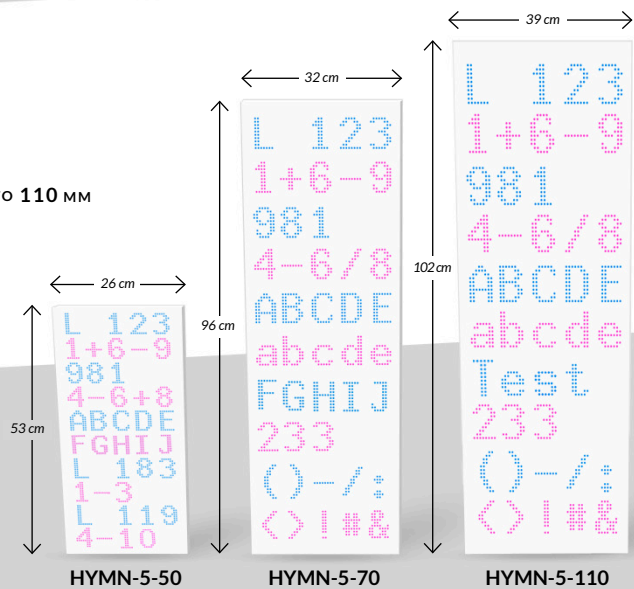

### Technical data (valid for basic systems & extension modules)

Type	HYMN-1 hymn boards (2-line)					HYMN-5 hymn boards (10-line)		
	HYMN-1-40*	HYMN-1-70	HYMN-1-100	HYMN-1-140	HYMN-1-180	HYMN-5-50	HYMN-5-70	HYMN-5-110
choir display	choir display	main display	main display	main display	main display	main display	main display	main display
Reading distance	up to 8-12 m	up to 15-20 m	up to 35-40 m	up to 50-55 m	up to 60-70 m	up to 12-15 m	up to 20-25 m	up to 35-45 m
Dimens. (WxHxD)	17 x 17 x 3 cm	32 x 16 x 3 cm	40 x 30 x 3 cm	48 x 32 x 3 cm	60 x 45 x 3 cm	26 x 53 x 3 cm	32 x 96 x 3.5 cm	39 x 102 x 3.5 cm
Weight	0.5 kg	0.9 kg	1.4 kg	2.3 kg	3.5 kg	1.9 kg	4.6 kg	7.5 kg
Number of LEDs	1,000	3,050	6,100	6,100	6,100	8,000	12,288	24,500
Digit height	40 mm	70 mm	100 mm	140 mm	180 mm	50 mm	70 mm	110 mm
Lines	2	2	2	2	2	10	10	10
Special characters	no	yes	yes	yes	yes	no	yes	yes

\* Only available as an extension module without radio transmitter (for combination with an existing main display)





HYMN series - Continued from previous page

**Basic systems**

**HYMN-1/5-APP & HYMN-1/5-E**

The 2- and 10-line hymn boards can be controlled either via a **tablet with a pre-installed app** (models from the **HYMN-1-APP** (2-line) and **HYMN-5-APP** (10-line) series) or via an **input device** (models from the **HYMN-1-E** (2-line) and **HYMN-5-E** (10-line) series), which is supplied as part of the set. These "basic systems" are equipped with a radio transmitter and a radio receiver and can be expanded with additional hymn boards ("extension modules").

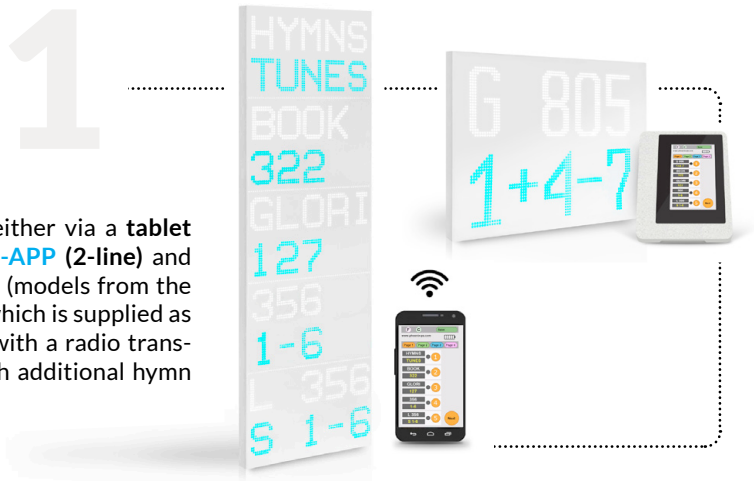

**Accessories**

**HYMN-1-APP** hymn boards (2-line)  
with control via **tablet incl. app** (basic systems)

**HYMN-5-APP** hymn boards (10-line)  
with control via **tablet incl. app** (basic systems)

	HYMN-1-70-APP	HYMN-1-100-APP	HYMN-1-140-APP	HYMN-1-180-APP	HYMN-5-50-APP	HYMN-5-70-APP	HYMN-5-110-APP
Radio transmitter	yes, built into all basic systems						
Tablet incl. app	yes, included in the set						

**HYMN-1-E** hymn boards (2-line)  
with control via **input device** (basic systems)

**HYMN-5-E** hymn boards (10-line)  
with control via **input device** (basic systems)

	HYMN-1-70-E	HYMN-1-100-E	HYMN-1-140-E	HYMN-1-180-E	HYMN-5-50-E	HYMN-5-70-E	HYMN-5-110-E
Radio transmitter	yes, built into all basic systems						
Input device	yes, included in the set						

**Extension modules**  
**HYMN-M**



Any number of **extensions (HYMN-M extension modules)** can be added to your basic system: You can add a choir display or another main display to your basic set, for example. When expanding your basic system, 2- and 10-line hymn boards can be **combined as desired**.

Almost **INFINITELY** expandable!

EXAMPLES:

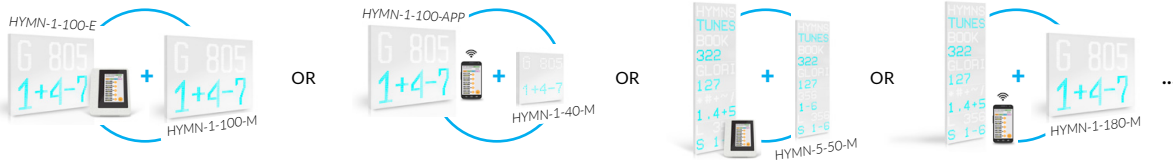

**NOTE:** The technical data of the extension modules are identical to those of the basic systems. However, the extension modules do not contain a radio transmitter or a tablet with an app or input device, as these accessories are already included in the basic sets.

**Accessories**

**HYMN-1-M** extension modules (2-line)

**HYMN-5-M** extension modules (10-line)

	HYMN-1-40-M	HYMN-1-70-M	HYMN-1-100-M	HYMN-1-140-M	HYMN-1-180-M	HYMN-5-50-M	HYMN-5-70-M	HYMN-5-110-M
Radio transmitter	Included in basic systems only;							
Tablet incl. app / Input device	not required for extension hymn boards							



HYMN series - Continued from previous page

## Control via tablet incl. app

HYMN-1-APP  
HYMN-5-APP

For the **HYMN-1-APP** (2 lines) and **HYMN-5-APP** (10 lines) hymn boards, we supply you with a 7" Android tablet with a pre-installed app. You can also download the app to any Android smartphone\*.

When controlling via app, you can **pre-enter up to 20 displays** alphanumerically and design them in color in **4 internal memories**.

The **brightness** of the LED board can also be individually adjusted via the app depending on the light incidence.

Another very useful feature of the app is the **timer function**, with which you can variably set the display duration (1 to 100 seconds).

In the standard configuration, our system **sets up its own WLAN**, which establishes the connection from the tablet to the gateway and then to the "HYMN" hymn boards.

When using the tablet, you only need to pay attention to the **transmission radius between the tablet and the gateway** to operate the hymn board. If the organist is to make the entries, the optimal location for the gateway is near the organ. The distance from the gateway to the hymn board is of secondary importance, but should not be affected too much by structural conditions.

For very large church spaces and / or massive concrete partitions, we offer additional **repeaters** that you can use to improve transmission if necessary. We also recommend using our **input device HYMN-E**.

Modern buildings and large churches increasingly have their **own WLAN** and / or a **complex control system**. Our technology is able to **integrate** the "HYMN" hymn boards into these systems.

The graphic "Gateway Types" (Appendix B) gives you an overview of the transmission options.

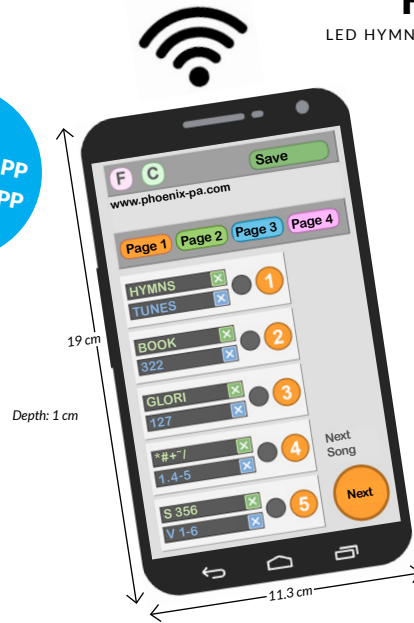

Fig.: up Connection to the hymn board: Radio transmitter (GATEWAY) with power supply

Fig.: below Example views of the setting options in the HYMN control app



### Technical data

### Technical data

	Gateway (radio transmitter)
WiFi	IEEE 802.11 b/g/n 2.4GHz (recept. fr. input device)
Radio transmit./receiver	Frequency 868 MHz (for hymn board)
Radio range in open field	approx. 200m
Power supply	5V/500mA (plug power supply / USB)
Power consumption	100mA/5V (average)
Dimensions	85 x 65 x 28 mm (W x H x D)
Weight	approx. 0.1 kg

	Tablet**
Brand	Lenovo
Model / series	TAB3 A7-10
Dimensions / Weight	19 x 11.3 cm / 299 g
Color	Black, blue
Type	Tablet
Screen size	7 inches
Screen resolution	1024 x 600 pixels
Processor speed	1.3 GHz
Processor cores	4
RAM size	1 GB
Memory technology	LPDDR3 SDRAM
Memory type	DDR4 SDRAM
RAM size	1 GB
Size of hard disc	8 GB
Hard disc	Flash
Audio output	3.5 mm
Chipset manufacturer	ARM
WLAN type	802.11B, 802.11G, 802.11n
Operating system	Android
Battery type	Lithium ion (Li-ion)
Battery life Ø	10 hours
Lithium battery capacity	50 watt hours

\* Download via the Google Playstore; Please note that separate fees apply for this. You will receive the activation code for the app with the sales documents.  
\*\* Example configuration - subject to availability.



HYMN series - Continued from previous page

## Control via input device



HYMN-1-E  
HYMN-5-E

**Traditional operation in a modern case:** To make it easier for you to switch from an older system to our innovative technology, we offer you an **input device for operating** our hymn boards (models **HYMN-1-E (2 lines)** and **HYMN-5-E (10 lines)**) as an alternative to the tablet.

The **touch display's** user interface is largely adapted to the classic control systems and offers you great freedom of operation in the church.

The robust and elegant input device is available in **five different colors:** white, white marble, gray, beige and black.

Depending on the ambience or your personal taste, you can **freely choose the color of the input device** – at no additional cost (e.g. color beige if the input device is placed on the wood-colored organ when operated by the organist).



Fig.: The HYMN input device in various colors / View from below.

### Technical data

	Input device
Display	5" TFT, Capacitive touch display
Battery	8V4 / 3000mAH Li-ion battery
Operating time	> 8 hours (with fully loaded battery)
Power consumption	Average 350mA at full display brightness
Features	Send LED, ON / OFF button, charging socket on the front
Dimensions	H-190 x W-155 x D-29 mm
Weight	approx. 590 g

## Good to know

When developing the input keyboard, we paid particular attention to making it **as easy and clear as possible to use** without any training or prior knowledge. This means that anyone can effortlessly transfer the desired song and verse numbers to the hymn board – whether via app or input device.



G 382  
1+4+5

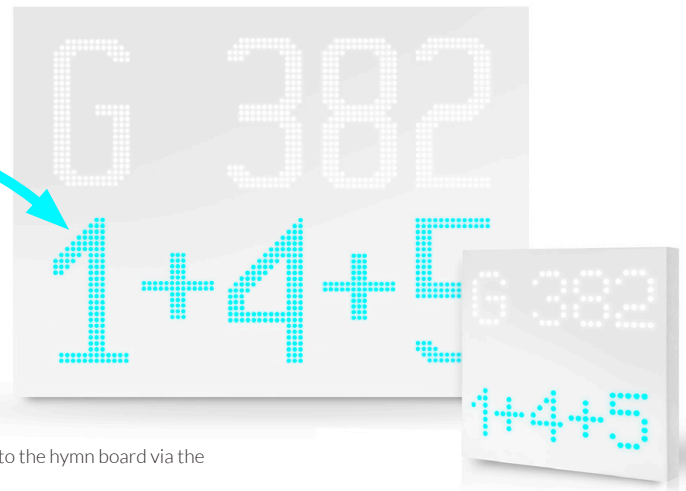

Fig.: Easy transfer of texts to the hymn board via the HYMN-E input device



HYMN series - Continued from previous page

## Accessories for wall mounting

The 180° wall swivel mount **HYMN-V-1** is included in the delivery of every hymn board. In most cases, this solution is sufficient.

For wall mounting, you can also use the optional wall swivel mounts **HYMN-V-2** (boom up to 47 cm) and **HYMN-V-3** (boom up to 98 cm) as well as the motor wall swivel mount **HYMN-MSH** with electric drive, operation via control app and remote control. We are happy to offer you special solutions on request.

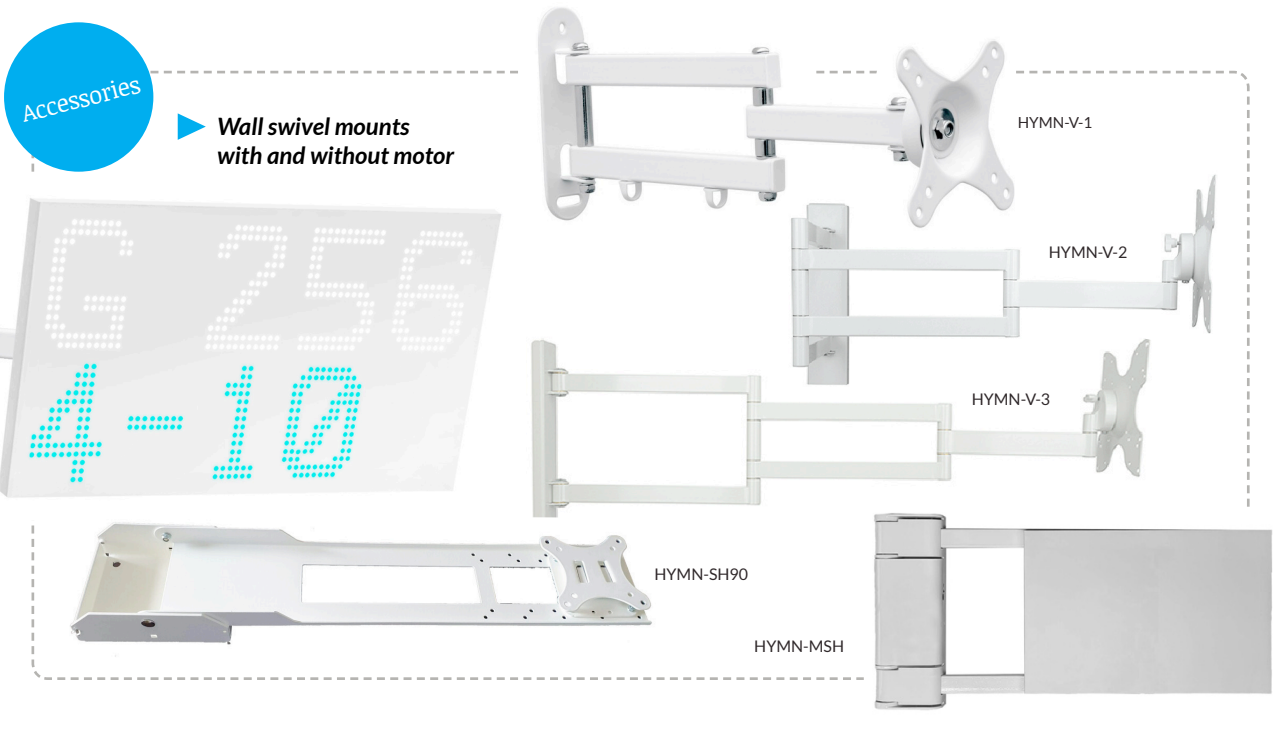

Accessories

Wall swivel mounts with and without motor

colors may vary. Subject to technical modifications, errors excepted.

GmbH | All rights reserved - Pictures, design and



The "HYMN" hymn boards are **designed for self-assembly**<sup>\*)</sup> and do not require any special technical knowledge.

The hymn boards can simply be hung on the wall like a picture. However, there are also **special structural conditions** with special installation situations for which we offer you the **appropriate accessories**.

You can use the hymn boards **mobile** in a chapel or outdoors (e.g. with a stand and a battery pack) or equip a church **stationary** (e.g. with a multi-swivelling wall mount).

Our systems are suitable for a **wide range of applications**. Choose the mounting solution that best suits your needs from a **wide range of mounting solutions!** We are happy to help you with the selection and planning.

## Good to know

The "HYMN" series is characterized by its **extremely easy installation**: the only structural requirement for installing each hymn board is a normal power connection.

Thus, you can easily install and commission the board **yourself**<sup>\*)</sup>.

The **power supply** is provided by a power supply pack with a **mains voltage of 220-240 VAC**.

**IMPORTANT NOTE:**  
**Operation with 115 VAC is possible on request** (e.g. for use in the USA).



Fig.: Hymn board with power pack for power supply

\* Unless structural changes need to be made (e.g. laying electricity)



HYMN series - Continued from previous page

**HYMN series**  
LED HYMN BOARDS FOR CHURCHES

## Accessories for stand mounting

Do you want to use the "HYMN" hymn boards in an environment without a power supply? Then the **stand mount** in combination with the **power battery sets** **HYMN-PB-1** (36W) and **HYMN-PB-2** (90W) is the perfect solution for you.

Fixed on a **stand**, such as the **HYMN-ST-1** (height up to 1.8 m) or **HYMN-ST-2** (height up to 2.4 m), and equipped with an unobtrusive power battery, the hymn boards can be operated completely independently, e.g. in **outdoor areas** or **small chapels**. The stand solution is also ideal for **listed buildings** and environments where wall mounting of hymn boards is not possible for certain reasons.

**IMPORTANT:** In order to attach the hymn board to the stand, the stand must be combined with a **VESA stand mount** (e.g. **HYMN-V-ST1**) and the **stand adapter** **HYMN-A-ST**.

All stands ensure a **safe and stable stand**, even when space is limited. They are available in white and black color.

**We are happy to offer you special solutions on request.**

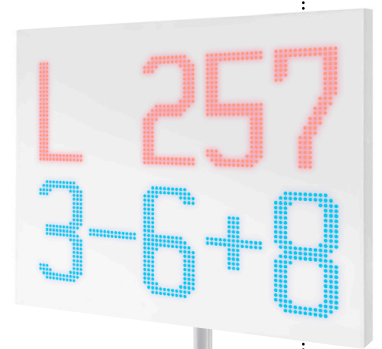

### Accessories

#### Power battery sets



HYMN-PB-1



HYMN-PB-2



HYMN-V-ST2



HYMN-A-ST

#### Stand adapters



HYMN-V-ST1

### ! Info

Our standard stand solutions are designed for the secure attachment of the **2-line hymn boards of the HYMN-1 series**. Please feel free to ask us about **special stand solutions for the HYMN-5 series**.

**We will find the right solution for you here too!**

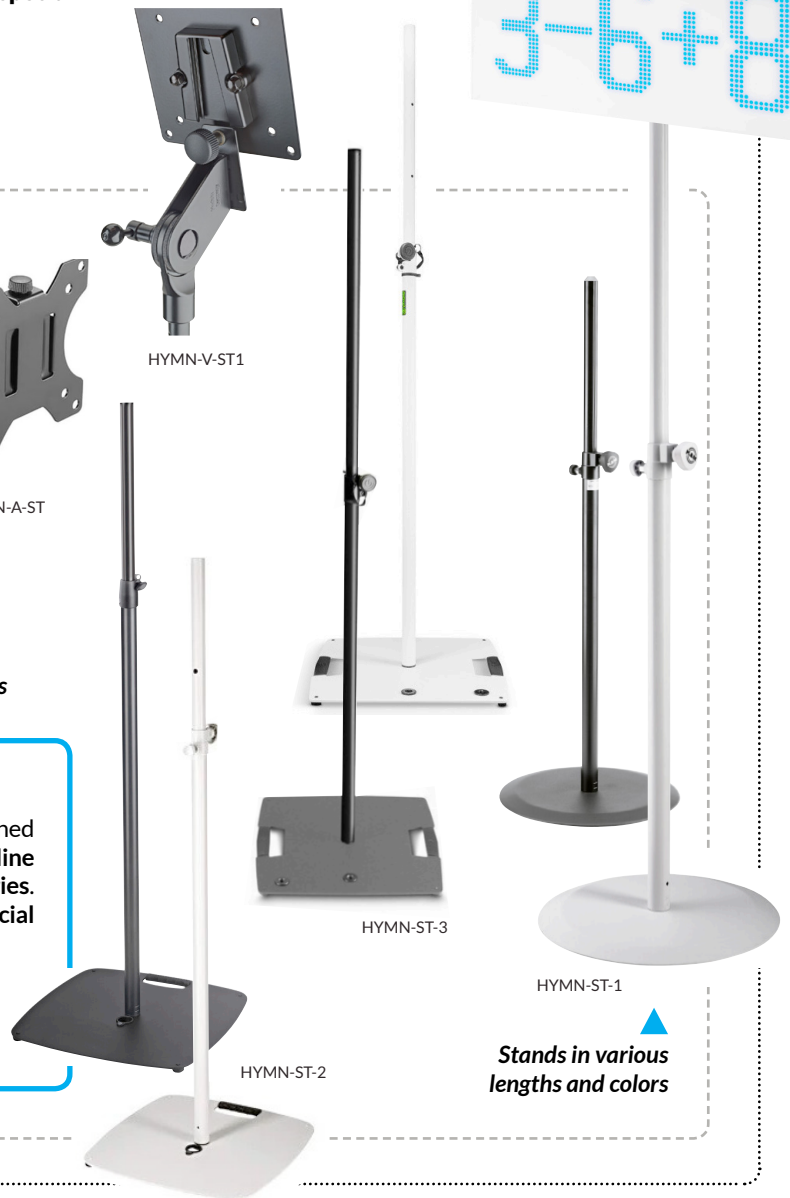

HYMN-ST-3

HYMN-ST-2

HYMN-ST-1

**Stands in various lengths and colors**



HYMN series - Continued from previous page

## Examples of application

Here you can see a small excerpt of installations of our "HYMN" hymn boards in churches:



Further product lines from our range and detailed information on the "HYMN" hymn boards can be found in our online shop at [>>](http://www.phoenix-pa.com/shop/PHOENIX-HYMN-series) and on our website at [>>](http://www.phoenix-pa.com/hymn-boards)

Do you have any questions?  
We're happy to advise you!

+49 8062 /  
9084984

Put your trust in the latest,  
unique display technology –  
take the right step into the future  
with the "HYMN" hymn boards



## Product overview

### HYMN-1 HYMN BOARDS (2-line)

<b>HYMN-1-40</b>	<b>2-line LED hymn board (choir display)</b> Reading distance approx. 8-12 m, dimensions: W-17cm x H-17cm x D-3cm
HYMN-1-40-M	Extension module
<b>HYMN-1-70</b>	<b>2-line LED hymn board (choir display)</b> Reading distance approx. 15-20 m, dimensions: W-32 cm x H-16 cm x D-3 cm
HYMN-1-70-APP	Version with tablet / software & app for control
HYMN-1-70-E	Version with input device for control
HYMN-1-70-X	Version without input device
HYMN-1-70-M	Extension module
<b>HYMN-1-100</b>	<b>2-line LED hymn board (main display)</b> Reading distance approx. 35-40 m, dimensions: W-40 cm x H-30 cm x D-3 cm
HYMN-1-100-APP	Version with tablet / software & app for control
HYMN-1-100-E	Version with input device for control
HYMN-1-100-X	Version without input device
HYMN-1-100-M	Extension module
<b>HYMN-1-140</b>	<b>2-line LED hymn board (main display)</b> Reading distance approx. 50-55 m, dimensions: W-48 cm x H-32 cm x D-3 cm
HYMN-1-140-APP	Version with tablet / software & app for control
HYMN-1-140-E	Version with input device for control
HYMN-1-140-X	Version without input device
HYMN-1-140-M	Extension module
<b>HYMN-1-180</b>	<b>2-line LED hymn board (main display)</b> Reading distance approx. 60-70 m, dimensions: W-60 cm x H-45 cm x D-3 cm
HYMN-1-180-APP	Version with tablet / software & app for control
HYMN-1-180-E	Version with input device for control
HYMN-1-180-X	Version without input device
HYMN-1-180-M	Extension module

### HYMN-5 HYMN BOARDS (10-line)

<b>HYMN-5-50</b>	<b>10-line LED hymn board (main display)</b> Reading distance approx. 12-15 m, dimensions: W-26 cm x H-53 cm x D-3 cm
HYMN-5-50-APP	Version with tablet / software & app for control
HYMN-5-50-E	Version with input device for control
HYMN-5-50-X	Version without input device
HYMN-5-50-M	Extension module
<b>HYMN-5-70</b>	<b>10-line LED hymn board (main display)</b> Reading distance approx. 20-25 m, dimensions: W-32 cm x H-96 cm x D-3.5 cm
HYMN-5-70-APP	Version with tablet / software & app for control
HYMN-5-70-E	Version with input device for control
HYMN-5-70-X	Version without input device
HYMN-5-70-M	Extension module



## Product overview

### HYMN-5 HYMN BOARDS (10-line) - continuation

<b>HYMN-5-110</b>	<b>10-line LED hymn board (main display)</b> Reading distance approx. 35-45 m, dimensions: W-39 cm x H-102 cm x D-3.5 cm
<b>HYMN-5-110-APP</b>	Version with tablet / software & app for control
<b>HYMN-5-110-E</b>	Version with input device for control
<b>HYMN-5-110-X</b>	Version without input device
<b>HYMN-5-110-M</b>	Extension module

### ACCESSORIES

<b>VESA wall mounts</b>	<b>Swivel arm with 2 joints</b> Continuously adjustable by max. 180°, extendable, tiltable by +/- 15°
<b>HYMN-V-1<sup>*)</sup></b>	Standard - VESA mount, wall distance 7-35 cm, color: white
<b>HYMN-V-2</b>	VESA mount with boom up to 47 cm, wall distance 8-47 cm, color: white
<b>HYMN-V-3</b>	VESA mount with boom up to 98 cm, wall distance 9.5-98.5 cm, color: white
<b>VESA wall mounts</b>	<b>Swivel arm with 1 joint</b> Continuously adjustable
<b>HYMN-SH90</b>	Wall swivel mount with quick-release VESA mount, color: white
<b>Motorized wall mounts</b>	<b>Swivel arm with 1 joint</b> Continuously adjustable by max. 90°, controlled via hymn board control app
<b>HYMN-MSH<sup>**)</sup></b>	Wall swivel mount with electric drive, W-63 to 99 cm x H-31 cm
<b>VESA mounts</b>	<b>For mounting on a wall swivel mount</b>
<b>HYMN-V-QR</b>	Quick release VESA mount, color: black
<b>Power battery sets</b>	<b>Battery + charger + adapter with connection cable for hymn board</b>
<b>HYMN-PB-1<sup>**)</sup></b>	Battery 36W, operating time: > 3 hours
<b>HYMN-PB-2</b>	Battery 90W, operating time: > 8 hours (HYMN-1 series) / > 3.5 hours (HYMN-5 series)
<b>Stands<sup>**)</sup></b>	<b>With 35 mm stand tube</b> Color: black or white
<b>HYMN-ST-1 s</b>	Stand with round cast-iron base, H-110 to 181 cm, color: black
<b>HYMN-ST-1 w</b>	Stand with round cast-iron base, H-110 to 181 cm, color: white
<b>HYMN-ST-2 s</b>	Stand with flat steel plate, H-140 to 240 cm, color: black
<b>HYMN-ST-2 w</b>	Stand with flat steel plate, H-140 to 240 cm, color: white
<b>HYMN-ST-3 s</b>	Stand with steel base, H-142 to 242 cm, color: black
<b>HYMN-ST-3 w</b>	Stand with steel base, H-142 to 242 cm, color: white
<b>VESA stand mounts<sup>**)</sup></b>	<b>Swivel arm with 1 joint</b> With connection for mounting on stands
<b>HYMN-V-ST1</b>	VESA stand mount with prism connection, swivel range: 250°, color: black
<b>HYMN-V-ST2</b>	VESA stand mount with pole mount bracket, swivel range: 180°, tilt: +/- 30°, color: black
<b>Stand adapter<sup>**)</sup></b>	<b>For fixing to the stand and for connecting to the stand mount</b> (mandatory for stand solution)
<b>HYMN-A-ST</b>	Stand adapter with threaded pin 3/8" x 12 mm & large clamping screw, color: black

\* Already included in delivery

\*\* Only suitable for HYMN-1 series.

Please feel free to contact us separately for stand solutions for the HYMN-5 series.



# Appendix

## Appendix A How the hymn board gateway works

Normal WLAN access point  
(with internet access etc.):

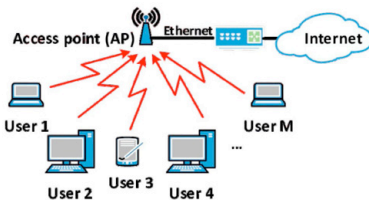

VS.

"Hymn board" WLAN access point  
(for control purposes only, without internet access):

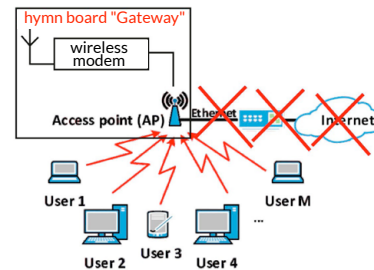

## Appendix B Gateway types

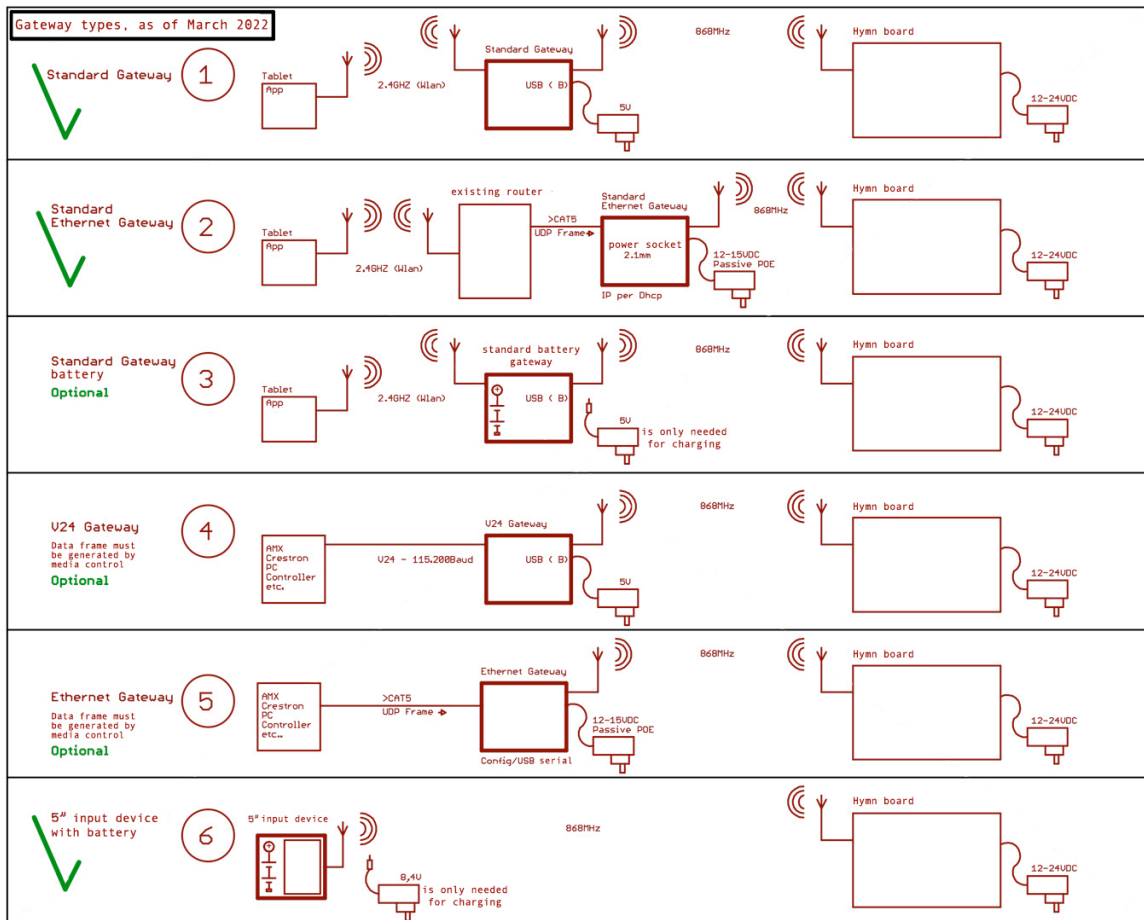

Fig.: Our technology is able to integrate the "HYMN" hymn boards into an existing WLAN and / or complex control system. The graphic above gives you an overview of the transmission options.



● **HYMN series** - Continued from previous page

## Notes

Large empty dotted-line box for notes.

---

### **Disclaimer**

*The author points out that the representations, explanations, calculations and the like contained in the product brochure are only of an exemplary nature. They reflect the current state of knowledge and the current legal situation, but do not claim to be complete.*

*In view of the complexity of construction projects, the development of individual solutions related to the respective project is essential.*

*Liability for all descriptions, applications, references and transfers of parts of the product brochure or individual information is hereby expressly excluded.*

### **Important instructions**

*The following applies to all pages of this description:*

*Subject to technical changes and printing errors.*

*The illustrations are similar, subject to color deviations.*



**ONLINE SHOP** *link:*



**[www.phoenix-pa.com](http://www.phoenix-pa.com) • [www.phoenix-pa.com/shop](http://www.phoenix-pa.com/shop)**

Tel.: +49 (0) 8062 908 49 84 | Fax: +49 (0) 8062 728 37 37 | E-Mail: [info@phoenix-pa.com](mailto:info@phoenix-pa.com)

**PHOENIX PROFESSIONAL AUDIO GMBH**

Hermann-Oberth-Str. 12  
83052 Bruckmühl  
Germany